

Full Absolute Linear Scale AT500-S/H Series

Bulletin No. 1766



**Exceptional speed and accuracy
enhances NC machine tool performance**

Mitutoyo

Full Absolute Linear Scale – AT500-S/H Series

The slim-design AT500-S/H Series Full Absolute Linear Scale has been enhanced to contribute significant improvements to the performance of NC machine tools.

A highly rigid design, the AT500 resists both vibration and impact. This, plus high-speed and the ability to tolerate temperature extremes, means the AT500 offers increased productivity for even the most demanding applications.

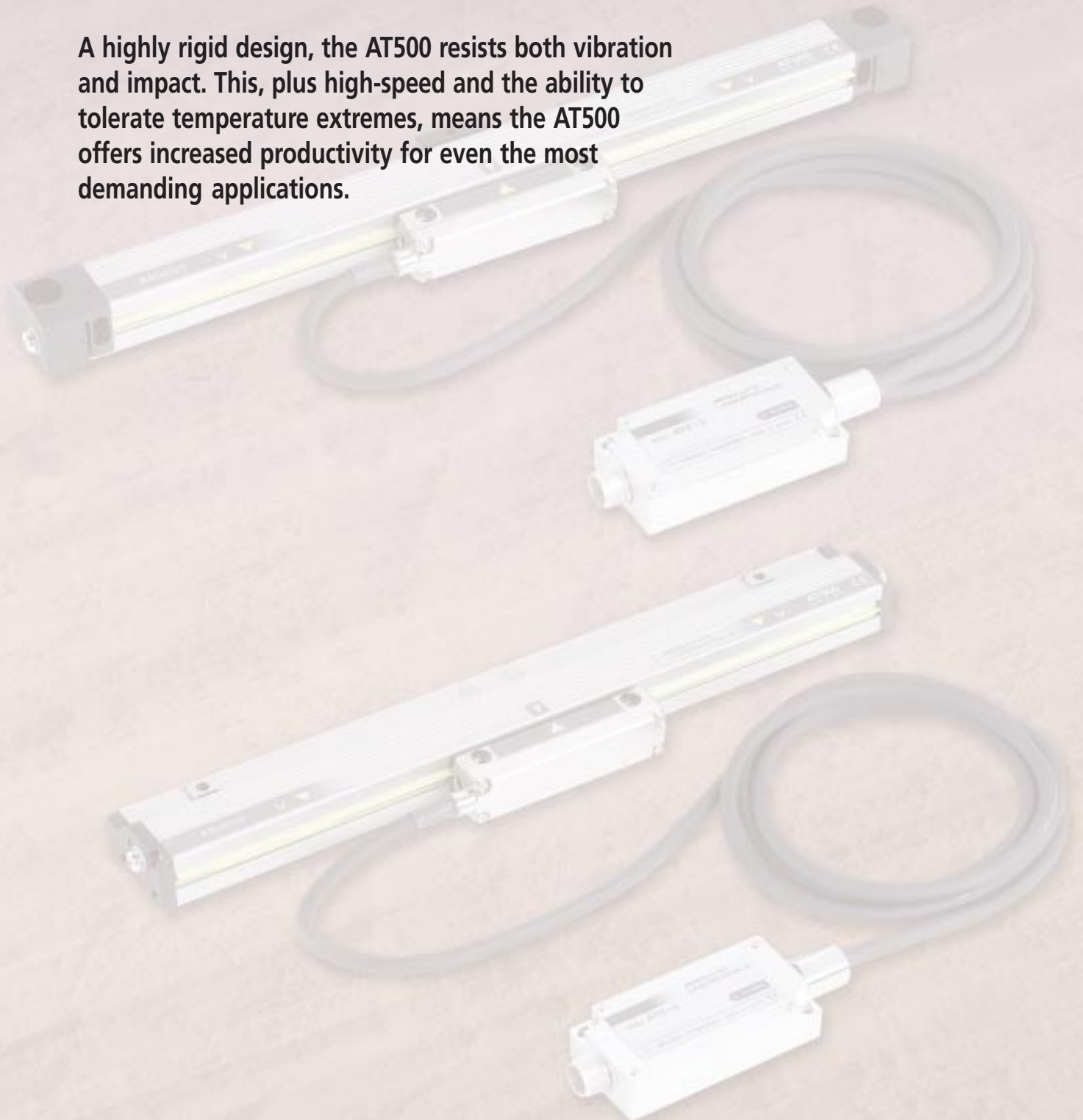

Overview

This Absolute Linear Scale has achieved the best-in-class response speed of 150m/min.

- Optimized for high-speed control of linear motors.

Implementation of High-rigidity [AT500-S Series]

- Has achieved the best-in-class vibration resistance of 20G and impact resistance of 35G in Absolute scale units.
- Available in safety for high-accuracy machining, high-speed machining, and heavy cutting due to accelerated rotation of the main spindle.
- Features increased tolerance to temperature variation for more stable operation.
- Twin servo control is optimized for large jobs and long run times such as machining of molds and similar complex parts..

Implementation of High-accuracy [AT500-H Series]

- Measuring accuracy: $2+2L/1000$ (μm)
- Improved accuracy/reproducibility through temperature compensation; datum point positioning is selectable.
- Appropriate for use with an NC lathe or an electric discharge machine (contributing to the improvement of machining accuracy).

Structural Features

The scale is compatible with both vibration/impact resistance and temperature characteristics. [AT500-S Series]

The combination of an optimized detector head structure and a scale main unit that employs multi-point elastic fixing with various analysis technologies has achieved excellent vibration/impact resistance and temperature characteristics.

1. Example of detector head structure analysis (FEM analysis)



2. Vibration resistance characteristics

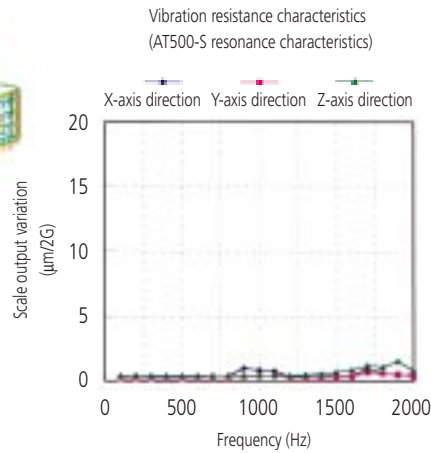

3. Example of impact resistance characteristics

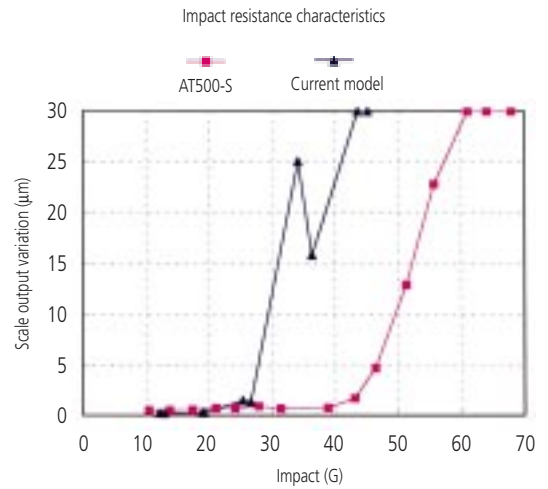

Excellent Temperature Characteristics and Improved Accuracy Reproducibility [AT500-H Series]

This series completely eliminates friction on the scale main unit, and employs an elastic fixing mechanism that has the "parallel leaf spring" function on both unit ends.

It has achieved excellent temperature characteristics and improved accuracy reproducibility.

4. Structure image

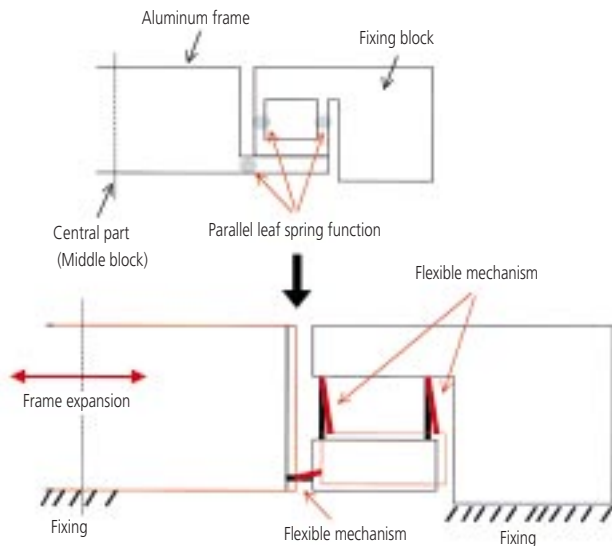

5. Temperature characteristics (example)

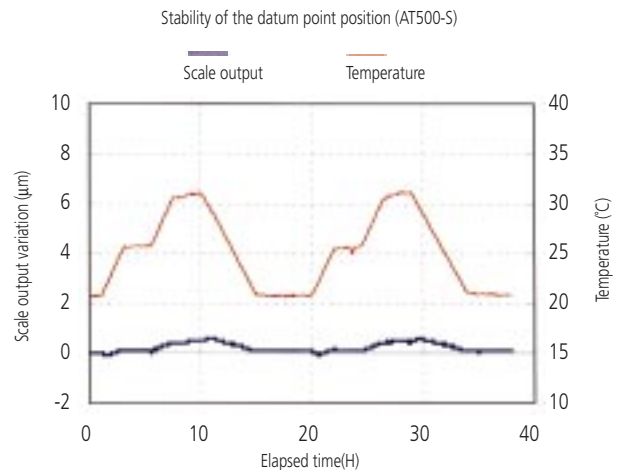

Note: "Datum point position of expansion"

The linear scale expands and contracts according to temperature variations. In this case the origin of mechanical expansion of the scale is defined as "Datum point position".

Full Absolute Linear Scale – AT500-SC, AT500-HC, AT500-HL/HR

Specifications

Item	High-rigidity type	High-accuracy type	
	AT500-SC	AT500-HC	AT500-HL/HR
Mounting method of the scale main unit	Multi-point elastic fixing	3 or 5-point elastic fixing	3 or 4-point elastic fixing
Datum point position of expansion to temperature variations	Center of effective measuring length		End of effective measuring range HL: (+ side end), HR: (- side end)
Effective measuring length	100 to 2200mm	100 to 1000mm	100 to 350mm
Detecting method	Electrostatic capacitance type/photoelectric type composite ABS linear encoder		
Resolution	0.05μm		
Maximum response speed	150m/min (2.5m/s)		
Accuracy (20°C)	3+3L/1000 (μm) L: effective measuring length (mm)	2+2L/1000 (μm) L: effective measuring length (mm)	
Thermal expansion coefficient	8.5±0.5 (10 ⁻⁶ /°C)		
Operating temperature/humidity	0 to 45°C, 20% to 80%RH (no condensation)		
Storing temperature/humidity	-20 to 70°C, 20% to 80%RH (no condensation)		
Vibration resistance	20G (55 to 2000Hz)	15G (55 to 2000Hz)	
Impact resistance	35G (1/2Sin 11ms)	20G (1/2Sin 11ms)	
Power supply	DC5V ±5%		
Maximum power consumption	270mA		
Maximum sliding force	4N		
Protection level	Scale main unit: Equivalent to IP53, I/F Box: Equivalent to IP54		
Alarm display function	A scale alarm is indicated with an LED on the I/F Box.		
Air supply orifice	Present		

Scale Structure

AT500-SC

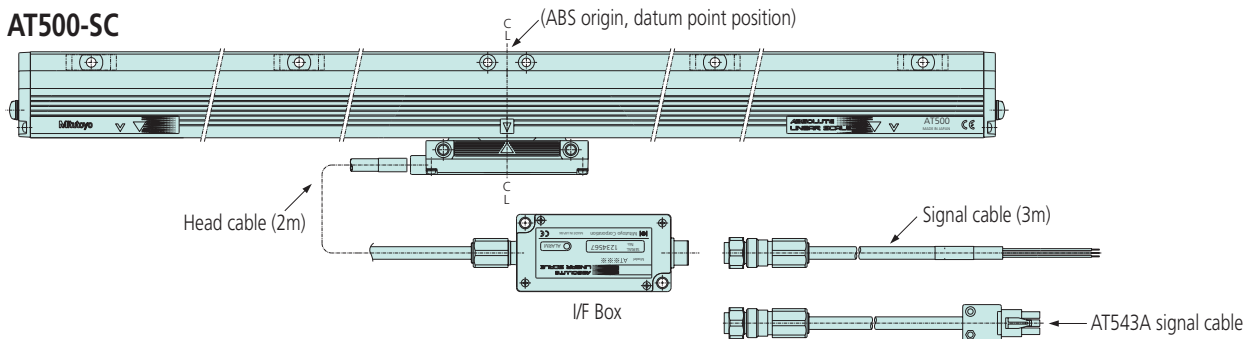

AT500-HC

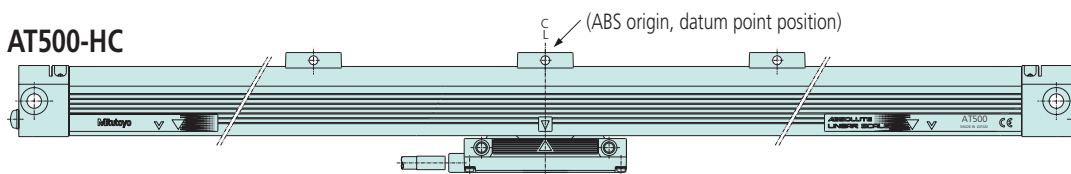

AT500-HL

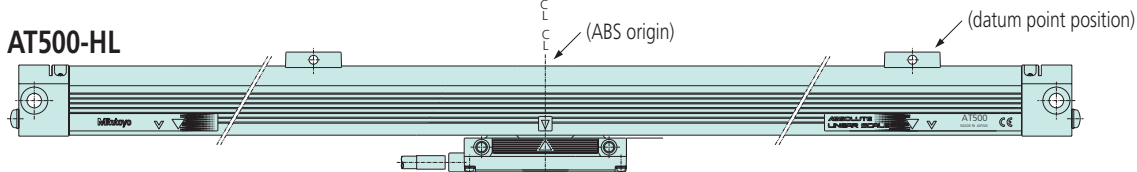

AT500-HR

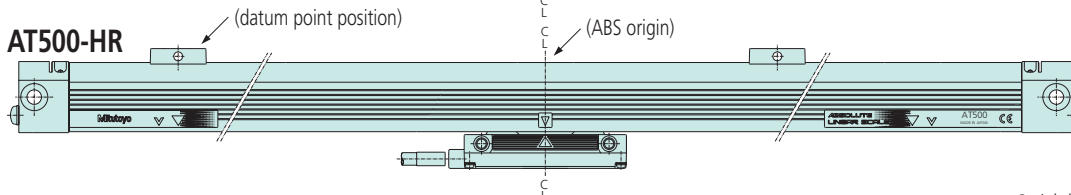

Serial data incremental direction
(during detector head displacement)

Scale type

Scale type	Interface
AT553	High-speed serial interface for FANUC LTD.
AT543	High-speed serial interface "MELDAS" for Mitsubishi Electric Corporation
AT543A	High-speed serial interface "MELSERVO" for Mitsubishi Electric Corporation
AT573A	High-speed serial interface "MINAS" for Matsushita Electric Industrial Co., Ltd.
AT503 AT503A	Mitutoyo standard serial interface

*AT5□□3□

Communication method
Blank: Full-duplex communication
A: Half-duplex communication

AT5□3□ - □□□□ - □□

Interface Effective measuring length

Scale main unit specification

S: High-rigidity type
H: High-accuracy type

Datum point position of expansion on the scale main unit *

C: Center of effective measuring range
L: End of effective measuring range (+ side end)
R: End of effective measuring range (- side end)

* L or R is appended to only the high-accuracy type.

System Configuration Example/Output Specification

AT553, AT543, AT573A, AT503, AT503A

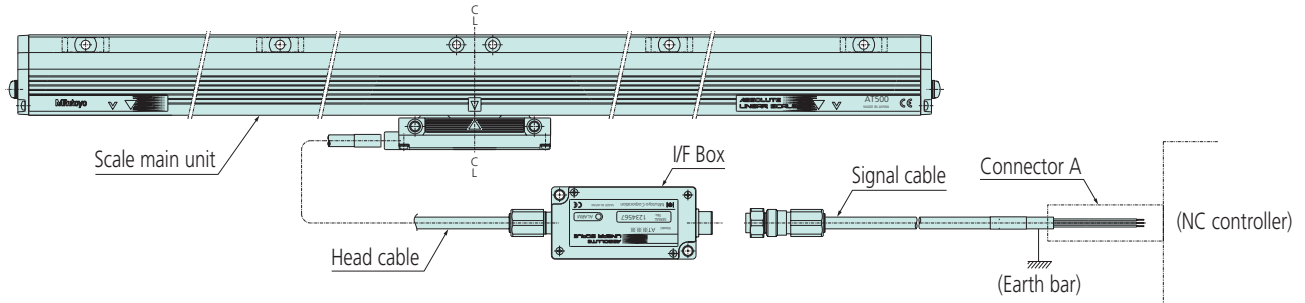

[Note]

1. Connector A is to be prepared by the client.
2. Connector A and the grounding bar are to be connected by the client.
3. If a cable is added between the signal cable lead wires and the control unit (e.g. a feedback cable is added), the maximum cable length (the total length of the head cable, signal cable, and feedback cable) is to be 29m.

Output specification

Wire color	signal	Wire color	signal
Brown/red	+5V	Blue	REQ
White/black	GND	Purple	Phase A
Orange	_SD	Gray	Phase B
Yellow	SD	Shielded	FG
Green	_REQ		

* Phase A and phase B are used as test signals. Use the signals while leaving them unconnected.

* Connect the shield wire to the grounding bar.

AT543A

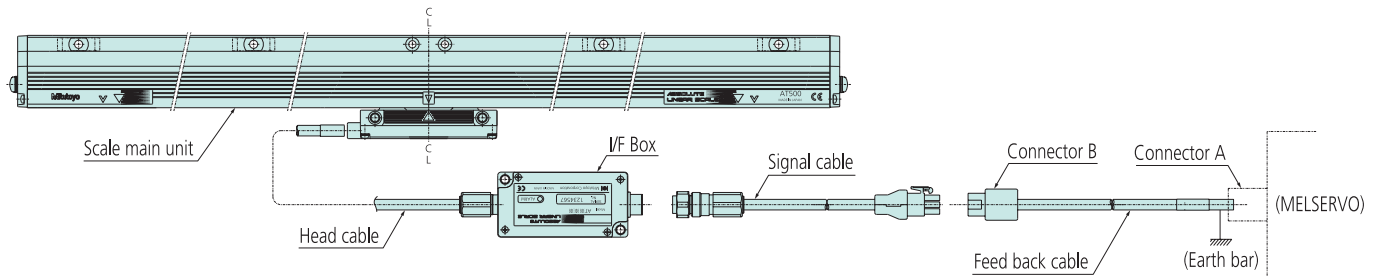

[Note]

1. Connectors A and B and feedback cables are to be prepared by the client.
2. Connectors A and B and the grounding bar are to be connected by the client.
3. An encoder cable made by Mitsubishi Electric Corporation can be used for the feedback cable.
Type: MR-JCCBL□M-H
A cable length (2, 5, or 10m) is indicated in "□".
*The feedback cable configuration differs depending on the system.
For detailed information, contact Mitsubishi Electric Corporation.
4. If a feedback cable is used, the maximum cable length (the total length of the head cable, signal cable, and feedback cable) is to be 29m.

Output specifications

Pin No.	Signal	Pin No.	Signal
1	MR (RQ/DT)	7	P5 (+5V)
2	MRR (*RQ/*DT)	8	LG (0V)
4	(DT)	9	F.G
5	(*DT)	3.6	N.C

* Applicable connector
Mini-Universal Mate-N-Lock Connector 9P (female) made by Tyco Electronics AMP
172161-9 (Housing, black)

Mitutoyo

Appearance and Dimensional Drawing

AT500-SC Series

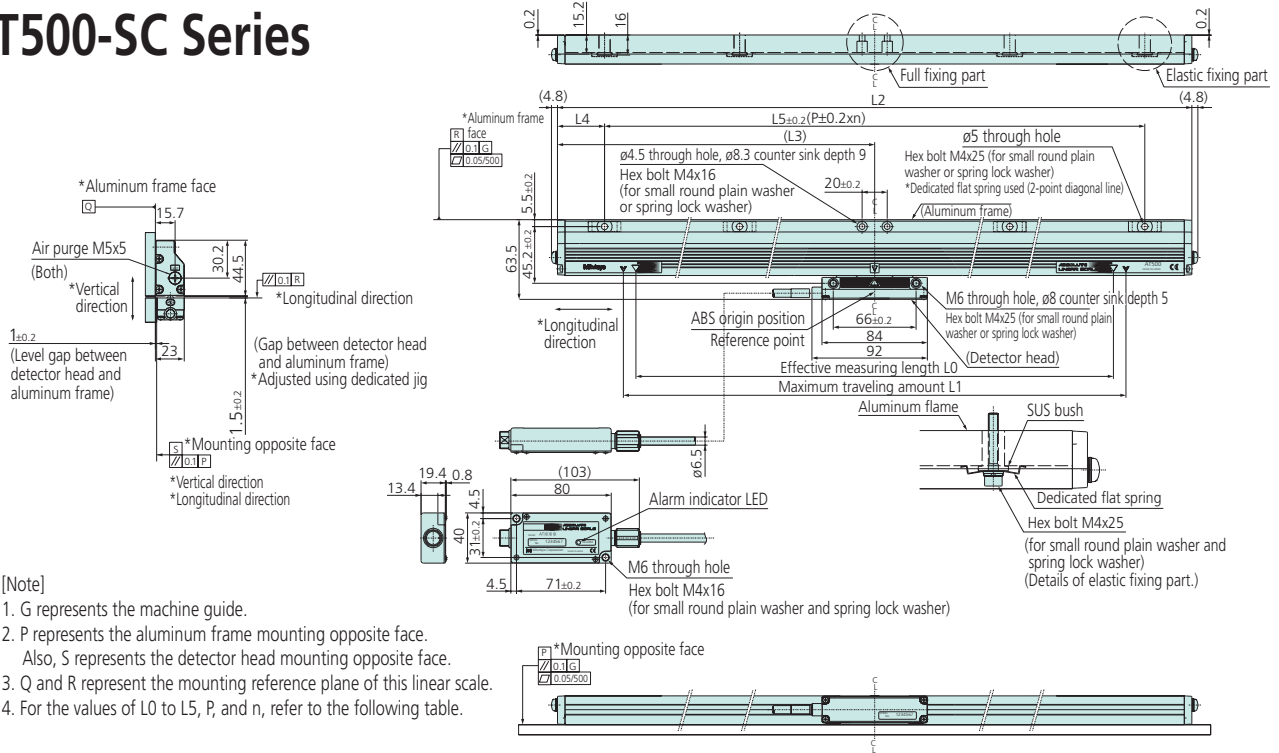

Table of AT500-SC Dimensions Unit: inch (mm)

L0	L1	L2	L3	L4	L5	P	n
4" (100)	4.72" (120)	8.86" (225)	4.43" (112.5)	1.48" (37.5)	5.91" (150)	2.95" (75)	2
8" (200)	8.66" (220)	12.80" (325)	6.40" (162.5)	1.48" (37.5)	9.84" (250)	4.92" (125)	2
12" (300)	12.60" (320)	16.73" (425)	8.37" (212.5)	1.48" (37.5)	13.78" (350)	6.89" (175)	2
16" (400)	16.54" (420)	20.67" (525)	10.33" (262.5)	2.46" (62.5)	15.75" (400)	7.87" (200)	2
20" (500)	20.47" (520)	24.61" (625)	12.30" (312.5)	2.46" (62.5)	19.69" (500)	4.92" (125)	4
24" (600)	24.41" (620)	28.54" (725)	14.27" (362.5)	2.46" (62.5)	23.62" (600)	5.91" (150)	4
28" (700)	28.35" (720)	32.48" (825)	16.24" (412.5)	2.46" (62.5)	27.56" (700)	6.89" (175)	4
32" (800)	32.28" (820)	36.42" (925)	18.21" (462.5)	2.46" (62.5)	31.50" (800)	7.87" (200)	4
36" (900)	36.22" (920)	40.35" (1025)	20.18" (512.5)	2.46" (62.5)	35.43" (900)	5.91" (150)	6
40" (1000)	40.16" (1020)	44.29" (1125)	22.15" (562.5)	1.48" (37.5)	41.34" (1050)	6.89" (175)	6
44" (1100)	44.09" (1120)	48.23" (1225)	24.11" (612.5)	3.44" (87.5)	41.34" (1050)	6.89" (175)	6
48" (1200)	48.03" (1220)	52.17" (1325)	24.27" (616.5)	2.46" (62.5)	47.24" (1200)	7.87" (200)	6
52" (1300)	51.97" (1320)	56.10" (1425)	28.05" (712.5)	4.43" (112.5)	47.24" (1200)	5.91" (150)	8
56" (1400)	55.91" (1420)	60.04" (1525)	30.02" (762.5)	2.46" (62.5)	55.12" (1400)	6.89" (175)	8
60" (1500)	59.84" (1520)	63.98" (1625)	31.99" (812.5)	4.43" (112.5)	55.12" (1400)	6.89" (175)	8
64" (1600)	63.78" (1620)	67.91" (1725)	33.96" (862.5)	2.46" (62.5)	62.99" (1600)	7.87" (200)	8
72" (1800)	71.65" (1820)	75.79" (1925)	37.89" (962.5)	3.44" (87.5)	68.90" (1750)	6.89" (175)	10
80" (2000)	79.53" (2020)	83.66" (2125)	41.83" (1062.5)	2.46" (62.5)	78.74" (2000)	7.87" (200)	10
88" (2200)	87.40" (2220)	91.54" (2325)	45.77" (1162.5)	4.43" (112.5)	82.68" (2100)	6.89" (175)	12

Appearance and Dimensional Drawing

AT500-HL/HR Series

Dimensional drawing of AT500-HL

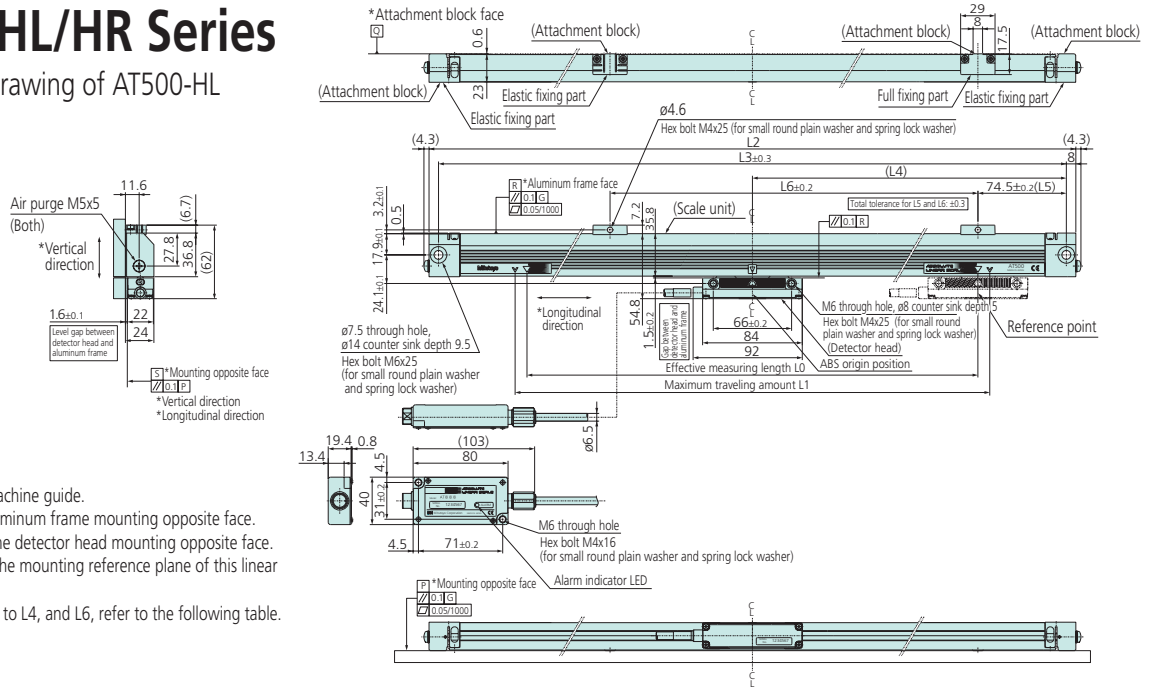

[Note]

- G represents the machine guide.
- P represents the aluminum frame mounting opposite face.
Also, S represents the detector head mounting opposite face.
- Q and R represent the mounting reference plane of this linear scale.
- For the values of L0 to L4, and L6, refer to the following table.

Dimensional drawing of AT500-HR

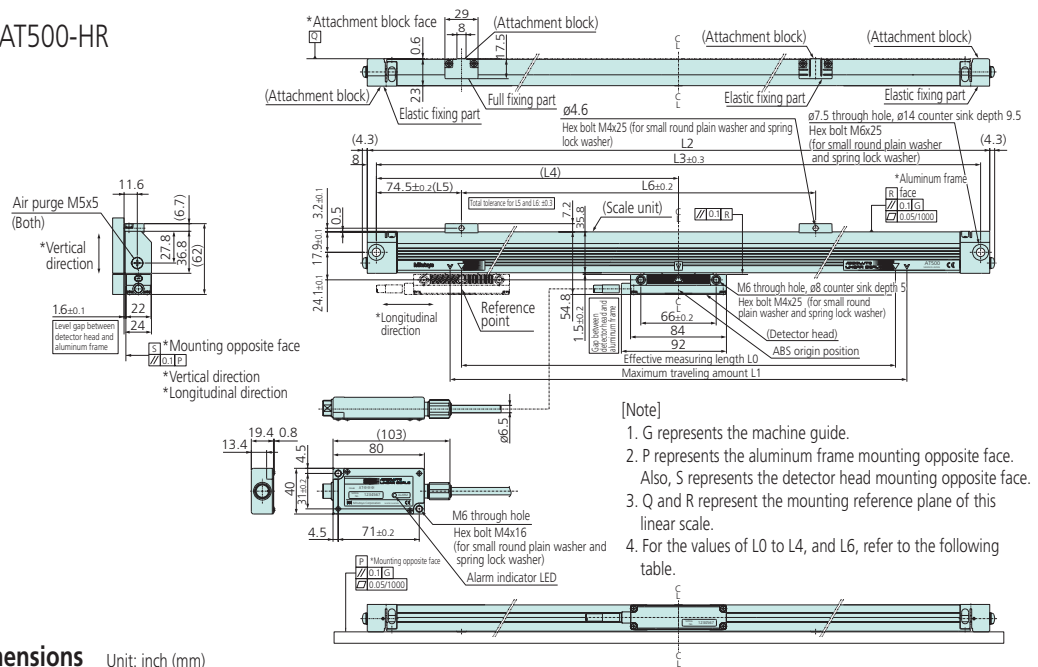

[Note]

- G represents the machine guide.
Also, S represents the detector head mounting opposite face.
- Q and R represent the mounting reference plane of this linear scale.
- For the values of L0 to L4, and L6, refer to the following table.

Table of AT500-HL/HR Dimensions Unit: inch (mm)

L0	L1	L2	L3	L4	L6
4" (100)	4.72" (120)	10.43" (265)	9.80" (249)	4.90" (124.5)	-
6" (150)	6.69" (170)	12.40" (315)	11.77" (299)	5.89" (149.5)	3.94" (100)
8" (200)	8.66" (220)	14.37" (365)	13.74" (349)	6.87" (174.5)	5.12" (130)
10" (250)	10.63" (270)	16.34" (415)	15.71" (399)	7.85" (199.5)	6.30" (160)
12" (300)	12.60" (320)	18.31" (465)	17.68" (449)	8.84" (224.5)	7.48" (190)
14" (350)	14.57" (370)	20.28" (515)	19.65" (499)	9.82" (249.5)	8.66" (220)

Mitutoyo

Appearance and Dimensional Drawing

AT500-HC Series

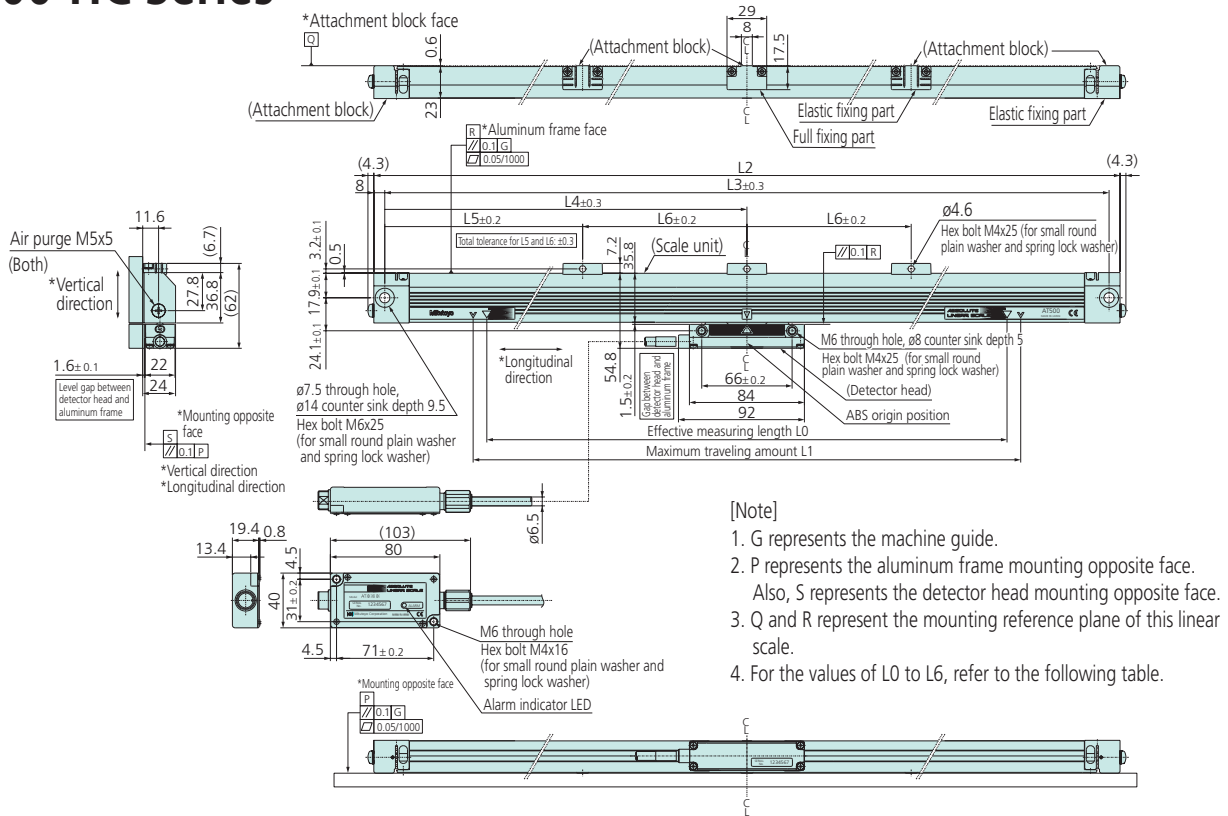
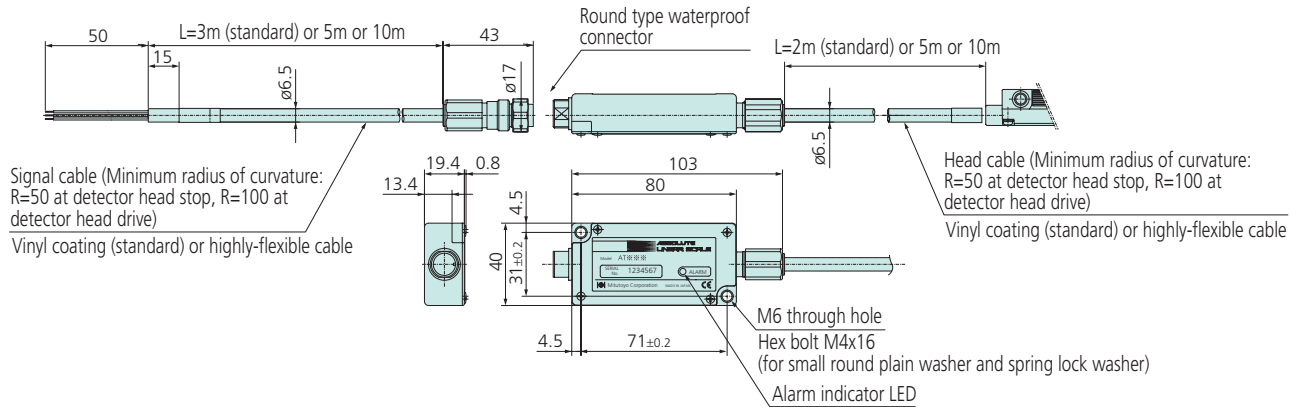

Table of AT500-HC Dimensions Unit: inch (mm)

L0	L1	L2	L3	L4	L5	L6
4" (100)	4.72" (120)	10.43" (265)	9.80" (249)	4.90" (124.5)	-	-
6" (150)	6.69" (170)	12.40" (315)	11.77" (299)	5.89" (149.5)	-	-
8" (200)	8.66" (220)	14.37" (365)	13.74" (349)	6.87" (174.5)	-	-
10" (250)	10.63" (270)	16.34" (415)	15.71" (399)	7.85" (199.5)	-	-
12" (300)	12.60" (320)	18.31" (465)	17.68" (449)	8.84" (224.5)	-	-
14" (350)	14.57" (370)	20.28" (515)	19.65" (499)	9.82" (249.5)	-	-
16" (400)	16.54" (420)	22.24" (565)	21.61" (549)	10.81" (274.5)	-	-
18" (450)	18.50" (470)	24.21" (615)	23.58" (599)	11.79" (299.5)	-	-
20" (500)	20.47" (520)	26.18" (665)	25.55" (649)	12.78" (324.5)	-	-
24" (600)	24.41" (620)	30.12" (765)	29.49" (749)	14.74" (374.5)	8.05" (204.5)	6.69" (170)
28" (700)	28.35" (720)	34.06" (865)	33.43" (849)	16.71" (424.5)	8.84" (224.5)	7.87" (200)
30" (750)	30.31" (770)	36.02" (915)	35.39" (899)	17.70" (449.5)	8.84" (224.5)	8.86" (225)
32" (800)	32.28" (820)	37.99" (965)	37.36" (949)	18.68" (474.5)	8.84" (244.5)	9.06" (230)
36" (900)	36.22" (920)	41.93" (1065)	41.30" (1049)	20.65" (524.5)	10.41" (264.5)	10.24" (260)
40" (1000)	40.16" (1020)	45.87" (1165)	45.24" (1149)	22.62" (574.5)	11.20" (284.5)	11.42" (290)

Drawings of Cable Dimensions

Lead wire type appearance and dimensional drawing



Appearance and dimensional drawing of AT543A type

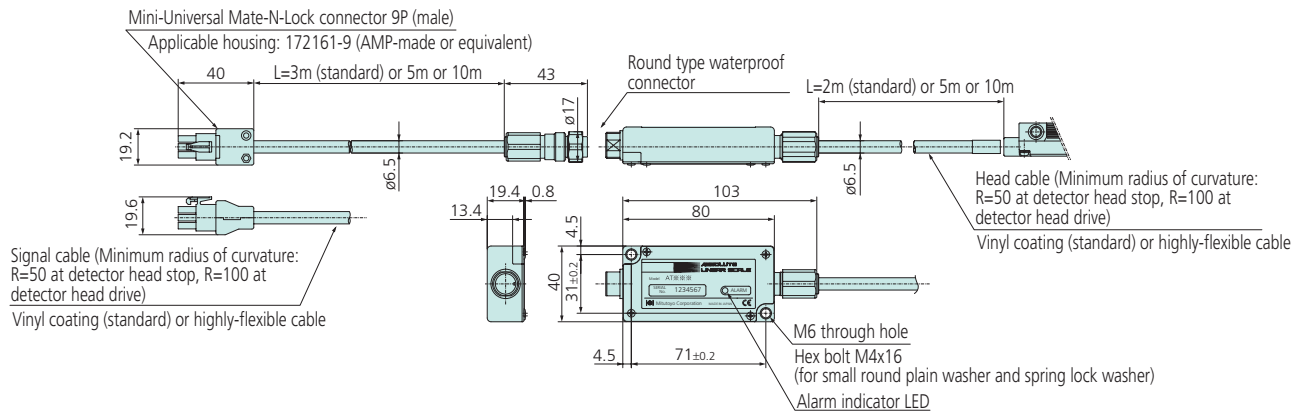



Note:

All our product details, in particular the illustrations, drawings, dimension and performance details and other technical specifications contained in this publication are to be considered to be approximate average values. To this extent, we reserve the right to make changes in design, technical data, dimensions and weight. Our specified standards, similar technical rules and technical specifications, descriptions and illustrations of the products are correct at the time of printing. The current version of our general terms and conditions also apply. Only offers which we have submitted can be considered to be definitive.

- Coordinate Measuring Machines
- Vision Measuring Systems
- Surface, Form and Contour Measurement
- Optical Measuring
- Sensor Systems
- Hardness Measuring
- Digital Scale and DRO Systems
- Small Tool Instruments and Data Management

Mitutoyo America Corporation

www.mitutoyo.com

M³ Solution Center

Michigan
(734) 459-2810

Massachusetts
(978) 692-8765

Illinois
(630) 978-5385

Indiana
(317) 577-6070

California
(626) 961-9661

No. Carolina
(704) 875-8332

Mitutoyo

Precision is our Profession